

Part Number	Max. Load Weight (kg)	Allowable moment *1 (N·m)	Retention Torque *2 (N·m)	Mass (g)
<b>DKSW-120-45-LD</b>	100	125	30	3200

- \*1: Allowable value for the eccentric load received from the control panel mounted on the rotating part.
- \*2: Retention torque is the reference maximum retention torque generated when tightening the clamp lever at the maximum clamping force (5.5kN) with no control panel mounted. The retention torque fluctuates in accordance with the tightening strength.
- Two stopper bolts are provided.

● Material/Finish

	<b>DKSW</b>
Main Body	Aluminum Alloy Electrostatic Coating (Matte Black)
Rotating Part	Cast Iron Low Temperature Black Chrome Treatment
Locating Plate	Steel Ferrosferic Oxide Film (Black)
Wedge Holder	Stainless Steel
Clamp Lever	Zinc Die Cast Electrostatic Coating (Matte Black)
Stopper Bolt	Steel Ferrosferic Oxide Film (Black)
Setscrew (Grease Inlet)	Steel Ferrosferic Oxide Film (Black)



● Related Products

**DKSP** stand pipes are available for height adjustment, used in combination with **DKSW**.



● Part Number Specification

**DKSW-120-45-LD**



- Unit used to fix and rotate control panels for machine tools, etc.
- Mount the control panel on the rotating part top.
- Control panel wiring can be passed through from the **DKSW** central hole.
- Tightening the clamp lever will lock the control panel rotation.
- Pulling the lever part of the clamp lever enables the lever part angle position to be arbitrarily changed after tightening.
- Mount the included stopper bolts at an arbitrary position on the **DKSW** bottom to restrict the locating plate rotation angle and set the control panel rotation angle. The rotation angle can be set within a range of 60° to 360°. For details, refer to the Rotation Angle Setting Table.

● Moment Load Generated from Control Panel and Operating Torque

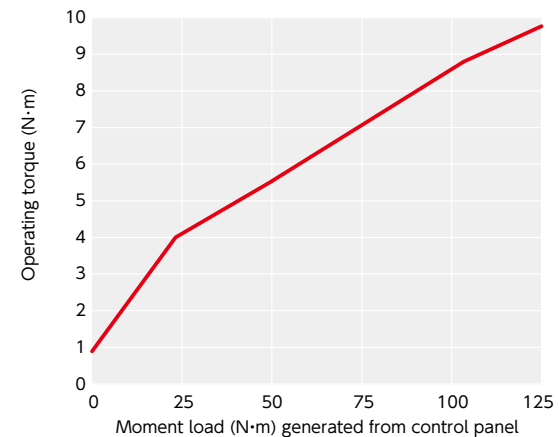

- The operating torque is the initial measured value and is not guaranteed for continued use.
- The operating torque when moment load is 0N·m is the value measured by unit with no control panel mounted.

● Durability Test Data

<Test Conditions>  
 Moment load generated from control panel : 125N·m  
 Operation of 1 cycle : Rotate the control panel about 60° and return it to the original position  
 Number of test cycles : 21,000  
 Additional greasing : None

<Operating Torque Change>

Before test : 10N·m  
 After test : 22N·m

⚠ Precautions for Use

- Use with the rotating part upward. Damage may occur if used in other orientations.
- When rotating the control panel, move it slowly so as not to apply impact to the stopper bolts. The stopper bolts may break under large impact, making it impossible to restrict the control panel rotation angle.
- When rotating the control panel, check that no one is in its vicinity. Injuries may occur if the control panel makes contact with persons nearby.
- When not using the stopper bolts, the control panel rotation will be unrestricted. Be careful not to twist the wiring.
- When installing the control panel to be used, calculate the moment load it generates. Installation is possible if the moment load generated from the control panel does not exceed the allowable moment value.

● Calculation Example of Moment Load Generated from Control Panel

<Conditions>

Operating panel mass : 30kg  
 Horizontal distance from swivel unit rotation axis to control panel center of gravity : 112mm

Control panel load  
 = Control panel mass x gravity acceleration  
 = 30kg x 9.8  
 = 294N

Moment load generated from control panel

= Horizontal distance from swivel unit rotation axis to control panel center of gravity x control panel load  
 = 0.112m x 294N  
 = 32.9N·m

As 32.9N·m < 125N·m, control panel installation is possible

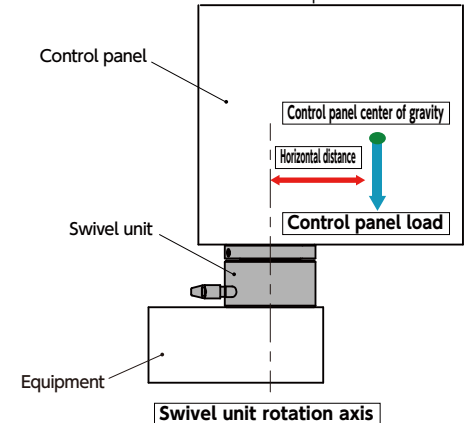

● Mounting

① When restricting control panel rotation angle\*1

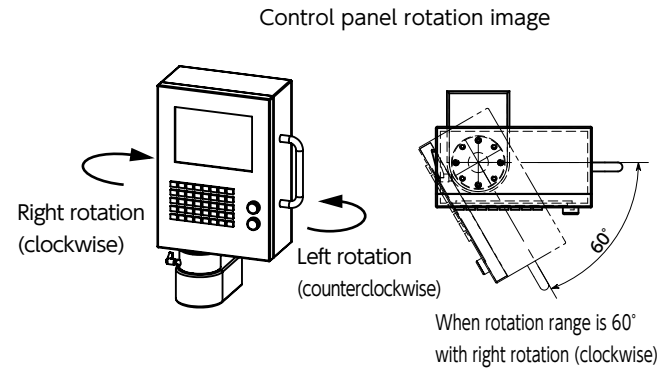
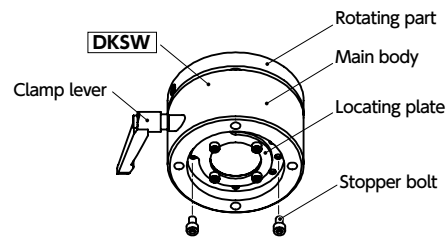

The control panel rotation angle can be restricted through a combination of the mounting position of the provided stopper bolts and the position of the locating plate.\*2

For the rotation angle setting, refer to the Rotation Angle Setting Table. With the clamp lever loosened, rotate the rotating part or the main body and mount the stopper bolts. (Reference tightening torque: 3N · m)

After setting the rotation angle, tighten the clamp lever in accordance with the reference position in the table and lock the rotation.

\*1: This process is not required when not restricting the control panel rotation angle.

\*2: Removal of the locating plate is not required.

② When fixing DKSW from the top

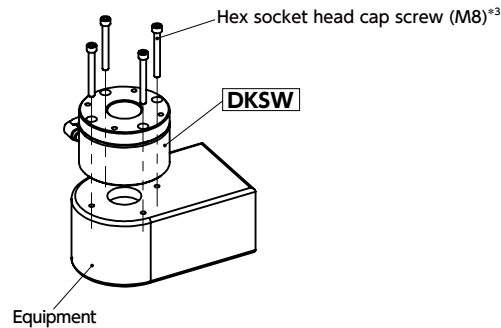

In order to pass the hex socket head cap screws (M8)\*3 through from above, align the rotating part through-hole and the main body counterbored hole phases with the clamp lever loosened. After aligning the phases, tighten the clamp lever and lock the rotation. Fix DKSW to the equipment with 4 hex socket head cap screws (M8)\*3.

③ Fix the control panel with 4 screws (M8)\*3.

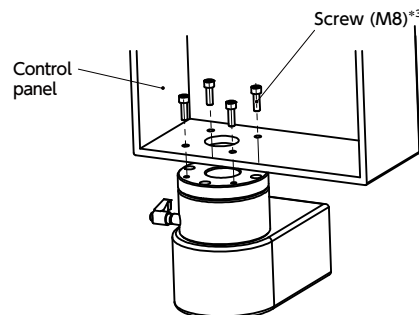

\*3: Screws are not supplied.

④ When fixing DKSW from the bottom

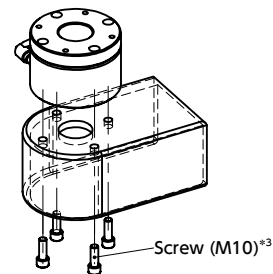

Fix DKSW with 4 screws (M10)\*3.

● Greasing Method

DKSW is filled with grease as of shipping. Greasing upon mounting is not required.

Perform maintenance in accordance with the usage conditions. Follow the procedure below when greasing.

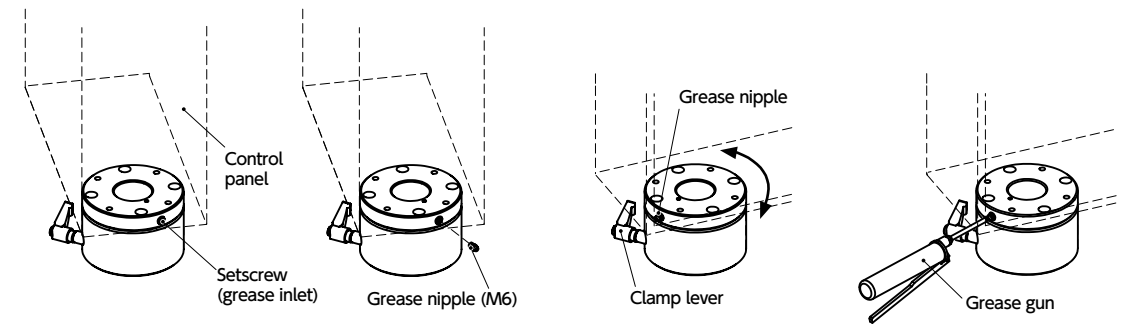

① Using a hex wrench\*1, remove the setscrew (grease inlet).

② Mount a grease nipple (M6)\*2 into the hole left by removing the setscrew.

③ After rotating the control panel to bring the grease nipple as close as possible to the clamp lever, tighten the clamp lever and lock the rotation.

④ Insert at least 5.5cc of grease\*3 with a grease gun.

\*1: The setscrew hex socket width across flat nominal is 3mm.

\*2: Grease nipple is not supplied.

\*3: Use lithium grease of consistency 1.