

● Material/Finish



	NQTBS
Main Body	Equivalent to SUS630
Hex Socket Head Cap Screw	Stainless Steel

- Dedicated cam base for mounting Quick Clamp Fasteners **NQTS** **NQTS-NI** **NQTS-F** **NQTS-F-NI**.
- The clamp part is tapered, making it easy to insert the Quick Clamp Fastener clamp pin.
- Made of stainless steel. It has excellent corrosion resistance.
- Two hex socket head cap screws for mounting are provided.

Part Number	H	L	D	t	B	R	Lc	E	Applicable Plate Thickness	Applicable Quick Clamp Fastener	Unit : mm
											Mass (g)
NQTBS-5	25	9	14	4.5	5	3	3	10	10~	NQTS-5-BK NQTS-5-F-BK NQTS-5-NI NQTS-5-F-NI	18
NQTBS-8	32	10	20	5.5	8	3.5	3.5	13	12~	NQTS-8-BK NQTS-8-L-BK NQTS-8-F-BK NQTS-8-NI NQTS-8-L-NI NQTS-8-F-NI	32

- Mounting
Align the phase of the Quick Clamp Fastener **NQTS** **NQTS-NI** **NQTS-F** **NQTS-F-NI** clamp pin and the **NQTBS** pin mounting hole for mounting.

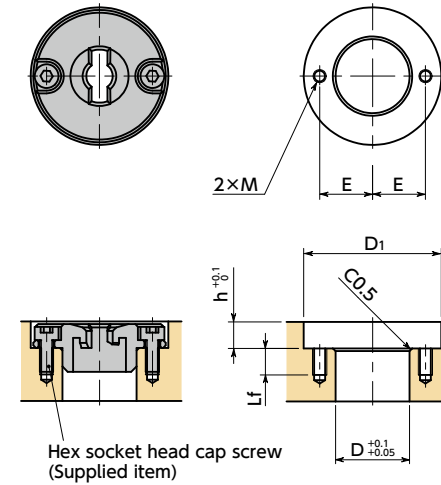

Part Number	D	D1	h	E	Lf	M (Coarse)	
						Nominal of Thread	Pitch
NQTBS-5	14	26	5	10	5	M2.5	0.45
NQTBS-8	20	33	6	13	5	M3	0.5

● Part Number Specification

NQTBS-8



Cleanroom Wash & Packaging Not Available	Laser Marking Not Available
---	--------------------------------