

# MOT Flexible Couplings - Oldham Type

High torque Electrical Insulation High Allowable Misalignment Small Eccentric Reaction Force

## Structure

### Set Screw Type

**MOT**

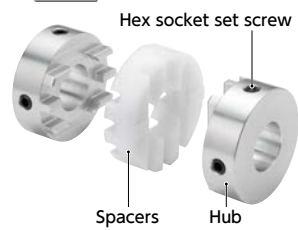

### Clamping Type

**MOT-C**



### Applicable Motors

	MOT
Servomotor	●
Stepping Motor	●
General-purpose Motor	◎

◎: Excellent ●: Available

### Property

	MOT
High Torque	◎
Allowable Misalignment	◎
Small Eccentric Reaction Force	◎
Allowable Operating Temperature	-20°C to 80°C

◎: Excellent

- Oldham-type flexible couplings compliant with the Japan Machine Accessory Association organizational standards (TES 1403).
- Slippage of hubs and a spacer allows large lateral and angular misalignment to be accepted.
- The eccentric reaction generated by misalignment is small and the burden on the shaft is reduced.
- The simple structure allows the unit to be easily assembled.

### Application

Transport conveyors / Mixers / Pumps

### Material/Finish



	MOT / MOT-C
Hub	A2017 Anodized*1
Spacers	Polyacetal
Hex Socket Set Screw	SCM435 Ferrosferric Oxide Film (Black)
Hex Socket Head Cap Screw	SCM435 Ferrosferric Oxide Film (Black)

\*1: With regard to bore surface treatment, process needs may result in a mixture of parts with and without surface treatment. This will not lead to any issues in terms of coupling performance.

### Part Number Specification

**MOT-63C-20-25**

Product Symbol    Size    Bore Diameter

Please refer to dimensional table for part number specification.

### Spacer's Projection Structure

Spacer's projection structure allows large angular misalignment to be effortlessly accepted. It reduces burden on the shaft.

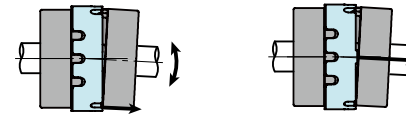

(Without projection)

(With projection)

For Oldham-type couplings with no spacer projection, the spacer and hubs interfere with each other near the outside diameter, so that the max. angular misalignment is small and bending moment arises on the shaft.

NBK's Oldham-type couplings allow angular misalignment to be easily accepted, as the projection serves as support. Bending moment does not arise. Therefore, the max. angular misalignment is large and the burden on the shaft is reduced.



Additional Keyway at Shaft Hole Available / Add'l charge	Cleanroom Wash & Packaging Not Available	SUS Change to Stainless Steel Screw Available / Add'l charge
---	---	---

# MOT-C Flexible Couplings - Oldham Type - Clamping Type

High torque × Electrical Insulation × High Allowable Misalignment × Small Eccentric Reaction Force

MOT-C

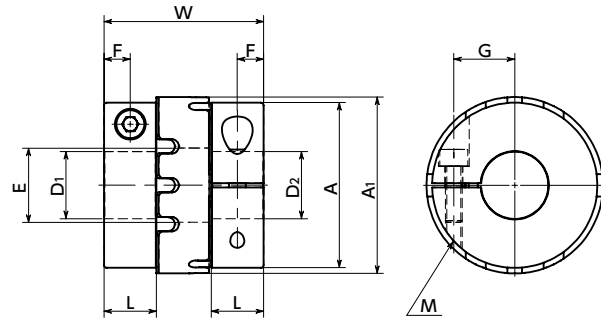

## Dimensions

Unit : mm

Part Number	A	A1	L	W	E	F	G	M	Screw Tightening Torque (N·m)
MOT-55C	51	55	13.8	46	21	6.9	18.5	M5	4
MOT-63C	59	63	18.7	57	26.5	9.4	21.8	M6	8
MOT-75C	73.5	75	24	77	35	12	27.5	M8	16

Part Number	Standard Bore Diameter D1 • D2													
	12	14	15	16	18	20	22	25	28	30	35	38	40	
MOT-55C	●	●	●	●	●	●	●	●						
MOT-63C				●	●	●	●	●	●	●				
MOT-75C						●	●	●	●	●	●	●	●	●

- All products are provided with hex socket head cap screw.
- Recommended tolerance for shaft diameters is h6 and h7.
- A set of hubs with set screw type for one side and clamping type for the other side and others are available upon request.
- For the shaft insertion amount to the coupling, see Mounting/maintenance.

## Performance

Part Number	Max. Bore Diameter (mm)	Keyway Additional Modification Max. Bore Diameter (mm)	Rated Torque*1 (N·m)	Max. Torque*1 (N·m)	Max. Rotational Frequency (min <sup>-1</sup> )	Moment of Inertia*2 (kg·m <sup>2</sup> )	Static Torsional Stiffness (N·m/rad)	Max. Lateral Misalignment (mm)	Max. Angular Misalignment (°)	Mass*2 (g)
MOT-55C	25	25	30	60	2000	6.9×10 <sup>-5</sup>	3100	3	3	170
MOT-63C	32	32	45	90	2000	1.5×10 <sup>-4</sup>	4900	4	3	270
MOT-75C	40	40	80	160	2000	4.7×10 <sup>-4</sup>	9800	4.5	3	540

- \*1 : Correction of rated torque and max. torque due to load fluctuation is not required.  
If ambient temperature exceeds 30°C, be sure to correct the rated torque and max. torque with temperature correction factor shown in the following table. The allowable operating temperature of MOT-C is -20°C to 80°C.  
The shaft's slip torque may be smaller than the coupling's rated torque depending on the shaft bore.
- \*2 : These are values with max. bore diameter.

### • Ambient Temperature / Temperature Correction Factor

Ambient Temperature	Temperature Correction Factor
-20°C to 30°C	1.00
30°C to 40°C	0.80
40°C to 60°C	0.70
60°C to 80°C	0.55

### ⚠ Precautions for Use

In case of mounting on D-cut shaft, be careful about the position of the D-cut surface of the shaft.

### • Part Number Specification

MOT-63C-20-25 1 Set

←1 ←2

MOT-63 - SPCR Single Spacer

Product Symbol Outside Diameter Single Spacer (A1 Dimension)

Additional Keyway at Shaft Hole Available / Add'l charge	Cleanroom Wash & Packaging Not Available	Change to Stainless Steel Screw Available / Add'l charge
---	---	---

# MOT Flexible Couplings - Oldham Type

High torque × Electrical Insulation High Allowable Misalignment Small Eccentric Reaction Force

## Technical Information

### Change in Static Torsional Stiffness Due to Temperature

This is a value under the condition where the static torsional stiffness at 20°C is 100%.

Changes in the static torsion spring constant within the operating temperature are shown in the graph. Before using the unit, be aware of the deterioration of responsiveness.

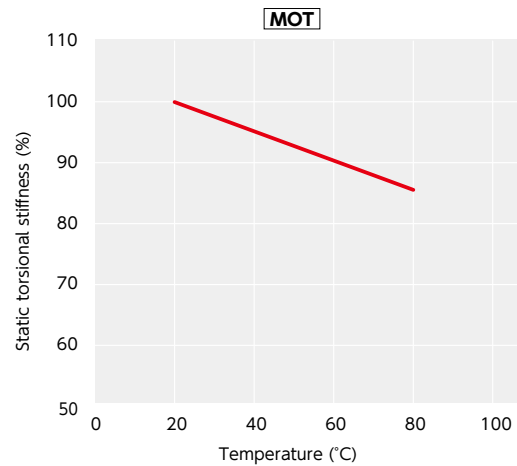

### Spacer's Physical Property (Polyacetal)

Test Method (ASTM)	Unit	Polyacetal
Dielectric Strength (3mm)	D149	kV/mm 19.0
Surface Resistance Value	D257	Ω 10 <sup>16</sup>
Combustibility (UL)	-	HB (0.75mm)

- Indicates the spacer (polyacetal) material properties and does not guarantee product performance.
- The combustibility is a value based on similar estimates from evaluation test results with reference to material information and UL standards.
- As properties change with usage conditions, carry out tests under performance conditions similar to actual conditions in advance.

### Spacer's Chemical Resistance (Polyacetal)

	Effect
Gasoline	△
Lubricant Oil	△
Benzine	×
Ethyl Alcohol	○
Acetone	△
Benzene	△
Toluene	△
Xylene	○

○: Almost no effect △: Available depending on conditions ×: Not available

- The data above does not indicate stress cracking resistance properties. Take sufficient precautions during usage under external stress.
- This is test data with a specimen used at room temperature (23°C). Chemical resistance changes with performance conditions. Always carry out tests under performance conditions similar to actual conditions in advance.

### Slip Torque

For set screw type **MOT**, see aluminum alloy couplings in "Couplings - Set Screw Type Slip Torque".

As in the table below, the clamping type **MOT-C** has different slip torque according to the bore diameter.

Take care during selection.

Unit: N·m

Part Number	Bore Diameter												
	12	14	15	16	18	20	22	25	28	30	35	38	40
<b>MOT-55C</b>	14	16	18	19	22	25	27	32					
<b>MOT-63C</b>				37	42	47	52	60	67	72			
<b>MOT-75C</b>						87	96	109	122	131	154	168	177

- These are test values based on the conditions of shaft dimensional allowance: g6, hardness: 58 HRC or higher, and screw tightening torque of the values described in **MOT-C** dimension tables. They are not guaranteed values.
- Slip torque changes with usage conditions. Carry out tests under conditions similar to actual conditions in advance.