

MOM-C Flexible Couplings - Oldham Type - Clamping Type Registered Design

High torque High Rigidity

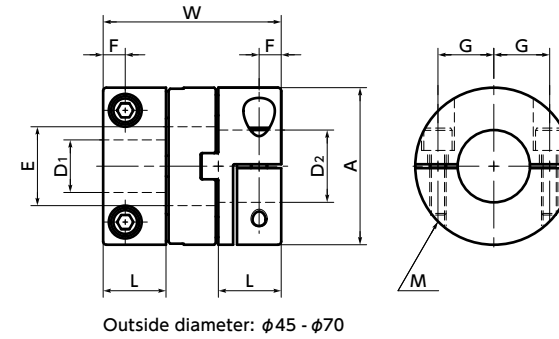
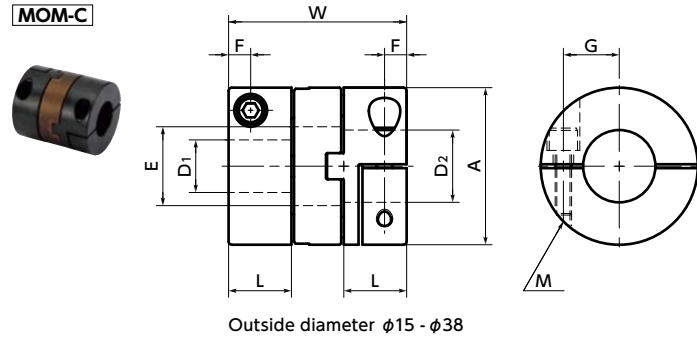

Dimensions

Unit : mm

Part Number	A	L	W	E	F	G	M	Screw Tightening Torque (N·m)
MOM-15C	15	6.6	19	6.9	2.15	5.2	M1.6	0.25
MOM-17C	17	9	25	7.3	2.65	5.5	M2	0.5
MOM-20C	20	10	28	11.1	3.25	7.25	M2.5	1
MOM-26C	26	11.5	31.6	13.3	4	9	M3	1.5
MOM-30C	30	12	34	15.5	4	11	M3	1.5
MOM-34C	34	13	35	17.5	4.5	12	M4	3.5
MOM-38C	38	15	40.5	21.5	4.75	14	M4	3.5
MOM-45C	45	16.2	47.6	24.3	6.2	16	M5	8
MOM-55C	55	20.8	58.6	27.7	7.9	20	M6	13
MOM-70C	70	25	68.6	38.5	8.9	26	M6	13

Part Number	Standard Bore Diameter D1/D2																			
	3	4	5	6	6.35	8	10	12	14	15	16	18	20	22	24	25	28	30	35	
MOM-15C	●	●	●	●																
MOM-17C		●	●	●																
MOM-20C			●	●	●	●	●													
MOM-26C				●	●	●	●	●												
MOM-30C					●	●	●	●	●											
MOM-34C						●	●	●	●	●										
MOM-38C							●	●	●	●	●	●	●							
MOM-45C								●	●	●	●	●	●	●						
MOM-55C									●	●	●	●	●	●	●	●	●			
MOM-70C										●	●	●	●	●	●	●	●	●	●	●

- All products are provided with hex socket head cap screw.
- Recommended tolerance for shaft diameters is h6 and h7.
- A set of hubs with set screw type for one side and clamping type or other type for the other side is available upon request.
- For the shaft insertion amount to the coupling, see Mounting/maintenance.

⚠ Precautions for Use

- In case of mounting on D-cut shaft, be careful about the position of the D-cut surface of the shaft. → P.xxxx
- There are sizes where the hex socket head bolt exceeds the outer diameter of the coupling and the rotating diameter is larger than the outer diameter. Please be careful of the interference of coupling. → P.xxxx

Additional Keyway at Shaft Hole → P.xxxx	Cleanroom Wash & Packaging → P.xxxx	Change to Stainless Steel Screw → P.xxxx
Available / Add'l charge	Not Available	Not Available

Performance

Part Number	Max. Bore Diameter (mm)	Keyway Additional Modification Max. Bore Diameter (mm)	Rated Torque *1 (N·m)	Maximum Torque *1 (N·m)	Max. Rotational Frequency (min ⁻¹)	Moment *2 of Inertia (kg·m ²)	Static Torsional Stiffness (N·m/rad)	Max. Lateral Misalignment *3 (mm)	Max. Angular Misalignment (°)	Mass *2 (g)
MOM-15C	6	6	3.3	6.6	2000	6.2×10 ⁻⁷	870	0.3	2	19
MOM-17C	6.35	6	5.5	11	2000	1.4×10 ⁻⁶	1300	0.3	2	34
MOM-20C	10	10	7.7	15.4	2000	3.0×10 ⁻⁶	1700	0.4	2	47
MOM-26C	12	12	11	22	2000	9.6×10 ⁻⁶	3200	0.5	2	92
MOM-30C	14	14	26	52	2000	1.8×10 ⁻⁵	4600	0.6	2	131
MOM-34C	16	16	35	70	2000	3.1×10 ⁻⁵	6000	0.7	2	173
MOM-38C	20	20	55	110	2000	5.5×10 ⁻⁵	7400	0.8	2	235
MOM-45C	22	22	66	132	2000	1.2×10 ⁻⁴	16000	1	2	387
MOM-55C	25	25	99	198	2000	3.4×10 ⁻⁴	30000	1.2	2	752
MOM-70C	35	35	176	352	2000	1.0×10 ⁻³	46000	1.4	2	1370

*1 : Values with no load fluctuation and rotation in a single direction. If there is large load fluctuation, or both normal and reverse rotation, select a size with some margin.

※ The shaft's slip torque may be smaller than the coupling's rated torque depending on the shaft bore. → P.xxxx

*2 : These are values with max. bore diameter.

*3 : The max. lateral misalignment varies depending on the load torque and revolution. → P.xxxx

• Comparison of rated torque

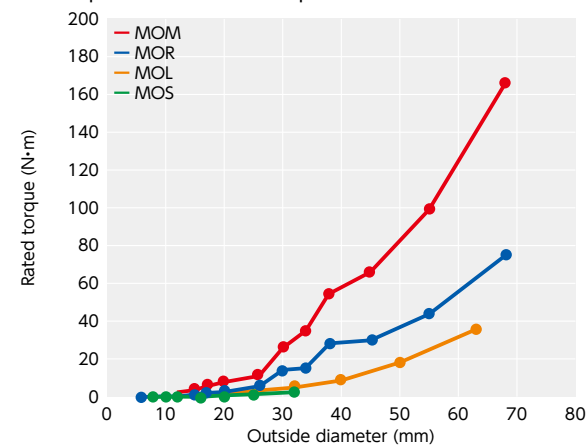

• Comparison of Static Torsional Stiffness

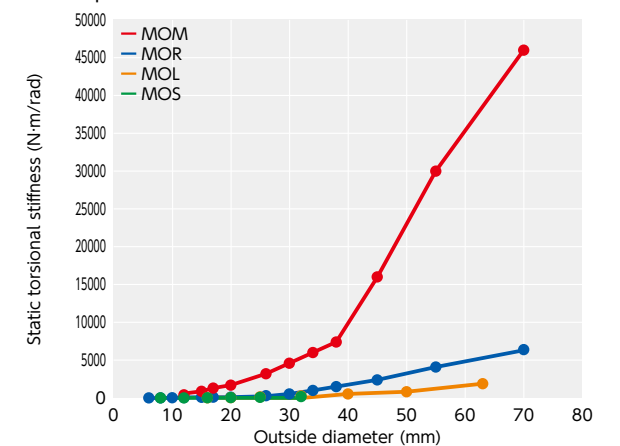

• Part number specification

MOM-55C-15-16