

MJC-CS Flexible Coupling - Jaw - Type - Clamping Type *Additional Size*

WEB Selection Tool | CAD Download | High torque | Vibration absorption | Electrical Insulation

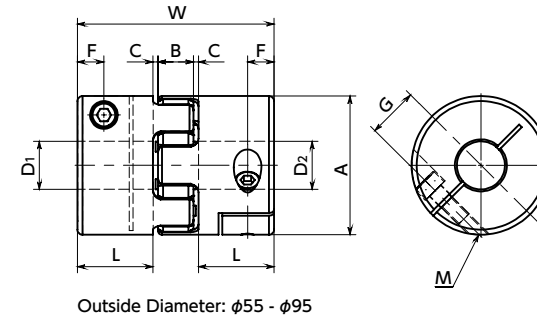

• Sleeve Details

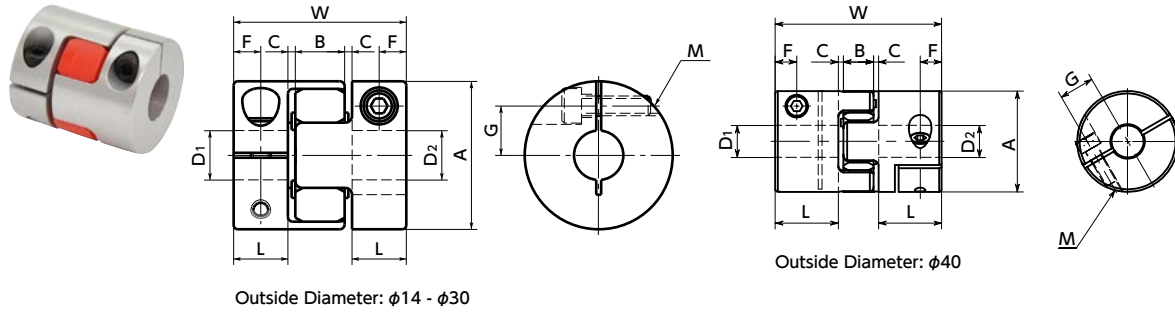
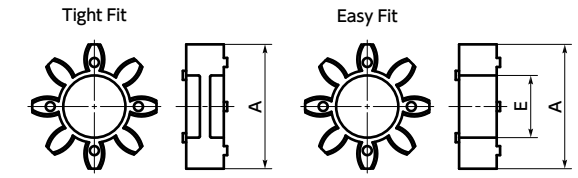

• Ambient Temperature / Temperature Correction Factor

Ambient Temperature	Temperature Correction Factor
-20°C to 30°C	1.00
30°C to 40°C	0.80
40°C to 60°C	0.70

Dimensions

Unit : mm

Part Number	Bore Diameter	A	L	W	B	C*1	Sleeve E	F	G	M	Screw Tightening Torque (N·m)
MJC-14CS	3 ≤ D ≤ 5	14	7	22	6	1	4	3.5	4	M2	0.5
	5 < D ≤ 7								5	M1.6	0.25
MJC-20CS	4 ≤ D ≤ 8	20	10	30	8	1	6	5	6.5	M2.5	1
	8 < D ≤ 11								7.5	M2	0.5
MJC-25CS	4 ≤ D ≤ 10	25	12	34	8	1	8	6	9	M3	1.5
	10 < D ≤ 12.7								9.5	M2.5	1
MJC-30CS	6 ≤ D ≤ 12	30	11	35	10	1.5	10	5.5	10	M4	3.5
	12 < D ≤ 16								11	M3	1.5
MJC-40CS	7.9375 ≤ D ≤ 20	40	25	66	12	2	17	8.5	14	M5	8
	20 < D ≤ 25								15.75	M4	3.5
MJC-55CS	9.525 ≤ D ≤ 28	55	30	78	14	2	26	10.5	20	M6	13
	28 < D ≤ 32								21	M5	8
MJC-65CS	12.7 ≤ D ≤ 32	65	35	90	15	2.5	29.5	13	24	M8	28
	32 < D ≤ 38.1								25	M6	13
MJC-80CS	19.05 ≤ D ≤ 42	80	45	114	18	3	35.5	15	30	M8	28
	42 < D ≤ 45								31	M8	28
MJC-95CS	25 ≤ D ≤ 48	95	50	126	20	3	44	18	34	M10	55
	48 < D ≤ 55								36	M10	55

*1: Use with C Dimension

Part Number	Standard metric bore diameter																																
	D1 · D2	3	4	4.5	5	6	6.35	7	8	9.525	10	11	12	14	15	16	18	19	20	22	24	25	28	30	32	35	38	40	42	45	48	50	55
MJC-14CS	●	●	●	●	●	●	●	●	●																								
MJC-20CS		●	●	●	●	●	●	●	●																								
MJC-25CS			●	●	●	●	●	●	●																								
MJC-30CS				●	●	●	●	●	●																								
MJC-40CS					●	●	●	●	●																								
MJC-55CS						●	●	●	●																								
MJC-65CS							●	●	●																								
MJC-80CS								●	●																								
MJC-95CS									●	●																							

Part Number	Standard inch bore diameter																																
	D1 · D2	1/8	3/16	1/4	5/16	3/8	7/16	1/2	9/16	5/8	11/16	3/4	13/16	7/8	15/16	1	1-1/8	1-1/4	1-3/8	1-1/2	1-5/8	1-3/4											
MJC-14CS	●																																
MJC-20CS		●																															
MJC-25CS			●																														
MJC-30CS				●																													
MJC-40CS					●																												
MJC-55CS						●																											
MJC-65CS							●																										
MJC-80CS								●																									
MJC-95CS									●																								

- All products are provided with hex socket head cap screw.
- Recommended dimensional allowances of applicable shaft diameter are h6 and h7.
- A set of hubs with clamping type for one side and set screw type or other type for the other side is available upon request.
- In case of mounting on D-cut shaft, be careful about the position of the D-cut surface of the shaft. → P.xxxx

Additional Keyway at Shaft Hole → P.xxxx | Cleanroom Wash & Packaging → P.xxxx | Change to Stainless Steel Screw → P.xxxx
 Available / Add'l charge | Available / Add'l charge | Available / Add'l charge

Performance

Part Number	Sleeve		Max. Bore Diameter (mm)	Rated*1 torque (N·m)	Max.*1 torque (N·m)	Zero Backlash*3 Allowable Transmission Torque (N·m)	Max. Rotational Frequency (min ⁻¹)	Moment*2 of Inertia (kg·m ²)	Static Torsional Stiffness (N·m/rad)	Max. Lateral Misalignment (mm)	Max. Angular Misalignment (°)	Max. Axial Misalignment (mm)	Mass*2 (g)	Sleeve Hardness (JIS)
	Tight Fit	Easy Fit												
MJC-14CS	BL	EBL	7	0.7	1.4	0.1	45000	1.9 x 10 ⁻⁷	8	0.15	1	+0.6 0	6.2	A80
MJC-20CS	BL	EBL	11	1.8	3.6	0.2	31000	1.0 x 10 ⁻⁶	16	0.2	1	+0.8 0	16	
MJC-25CS	BL	EBL	12.7	3	6	0.4	25000	3.2 x 10 ⁻⁶	32	0.2	1	+0.9 0	34	
MJC-30CS	BL	EBL	16	4	8	0.5	21000	6.0 x 10 ⁻⁶	46	0.2	1	+1.0 0	42	
MJC-40CS	BL	EBL	25	4.9	9.8	1.2	15000	3.6 x 10 ⁻⁵	380	0.15	1	+1.2 0	130	
MJC-55CS	BL	EBL	32	17	34		11000	1.6 x 10 ⁻⁴	1400	0.2	1	+1.4 0	310	
MJC-65CS	BL	EBL	38.1	46	92		9000	3.5 x 10 ⁻⁴	2800	0.2	1	+1.5 0	500	
MJC-80CS	BL	EBL	45	95	190		7000	1.0 x 10 ⁻³	3200	0.2	1	+1.8 0	1000	
MJC-95CS	BL	EBL	55	130	260		6000	2.3 x 10 ⁻³	3600	0.2	1	+2.0 0	1600	
MJC-14CS	WH	EWL	7	1.2	2.4	0.1	45000	1.9 x 10 ⁻⁷	14	0.1	1	+0.6 0	6.2	A92
MJC-20CS	WH	EWL	11	3	6	0.2	31000	1.0 x 10 ⁻⁶	29	0.15	1	+0.8 0	16	
MJC-25CS	WH	EWL	12.7	5	10	0.4	25000	3.2 x 10 ⁻⁶	60	0.15	1	+0.9 0	34	
MJC-30CS	WH	EWL	16	7.5	15	0.5	21000	6.0 x 10 ⁻⁶	73	0.15	1	+1.0 0	42	
MJC-40CS	WH	EWL	25	10	20	1.2	15000	3.6 x 10 ⁻⁵	570	0.1	1	+1.2 0	130	
MJC-55CS	WH	EWL	32	35	70		11000	1.6 x 10 ⁻⁴	1600	0.15	1	+1.4 0	310	
MJC-65CS	WH	EWL	38.1	95	190		9000	3.5 x 10 ⁻⁴	3000	0.15	1	+1.5 0	500	
MJC-80CS	WH	EWL	45	190	380		7000	1.0 x 10 ⁻³	5300	0.15	1	+1.8 0	1000	
MJC-95CS	WH	EWL	55	265	530		6000	2.3 x 10 ⁻³	6200	0.15	1	+2.0 0	1600	
MJC-14CS	RD	ERD	7	2	4	0.1	45000	1.9 x 10 ⁻⁷	22	0.1	1	+0.6 0	6.2	A98
MJC-20CS	RD	ERD	11	5	10	0.2	31000	1.0 x 10 ⁻⁶	55	0.1	1	+0.8 0	16	
MJC-25CS	RD	ERD	12.7	7.2	14.4	0.4	25000	3.2 x 10 ⁻⁶	120	0.1	1	+0.9 0	34	
MJC-30CS	RD	ERD	16	12.7	25	0.5	21000	6.0 x 10 ⁻⁶	130	0.1	1	+1.0 0	42	
MJC-40CS	RD	ERD	25	17	34	1.2	15000	3.6 x 10 ⁻⁵	1200	0.1	1	+1.2 0	130	
MJC-55CS	RD	ERD	32	60	120		11000	1.6 x 10 ⁻⁴	2600	0.1	1	+1.4 0	310	
MJC-65CS	RD	ERD	38.1	160	320		9000	3.5 x 10 ⁻⁴	4900	0.1	1	+1.5 0	500	
MJC-80CS	RD	ERD	45	325	650		7000	1.0 x 10 ⁻³	6500	0.1	1	+1.8 0	1000	
MJC-95CS	RD	ERD	55	450	900		6000	2.3 x 10 ⁻³	8900	0.1	1	+2.0 0	1600	
MJC-14CS	GR	EGR	7	2.4	4.8	0.1	45000	1.9 x 10 ⁻⁷	66	0.08	1	+0.6 0	6.2	D64
MJC-20CS	GR	EGR	11	6	12	0.2	31000	1.0 x 10 ⁻⁶	87	0.08	1	+0.8 0	16	
MJC-25CS	GR	EGR	12.7	9.6	19.2	0.4	25000	3.2 x 10 ⁻⁶	160	0.08	1	+0.9 0	34	
MJC-30CS	GR	EGR	16	16	32	0.5	21000	6.0 x 10 ⁻⁶	200	0.08	1	+1.0 0	42	
MJC-40CS	GR	EGR	25	21	42	1.2	15000	3.6 x 10 ⁻⁵	3000	0.08	1	+1.2 0	130	
MJC-55CS	GR	EGR	32	75	150		11000	1.6 x 10 ⁻⁴	9000	0.08	1	+1.4 0	310	
MJC-65CS	GR	EGR	38.1	200	400		9000	3.5 x 10 ⁻⁴	13000	0.08	1	+1.5 0	500	
MJC-80CS	GR	EGR	45	405	810		7000	1.0 x 10 ⁻³	14000	0.08	1	+1.8 0	1000	
MJC-95CS	GR	EGR	55	560	1120		6000	2.3 x 10 ⁻³	15000	0.08	1	+2.0 0	1600	

- *1: Correction of rated torque and max. torque due to load fluctuation is not required. However, if ambient temperature exceeds 30°C, be sure to correct the rated torque and max. torque with temperature correction factor shown in the table. MJCS's allowable operating temperature is -20°C to 60°C.
- *2: These are values with max. bore diameter.
- *3: For transmission with Zero Backlash, please use a tight fit sleeve.

• Part number specification

