

DFKM-AF Ball Joint (Male Screw) - Bolt Mounting NEW

WEB Selection Tool
 WEB CAD Download
 Aluminum frame mount
 wall/panel Mount

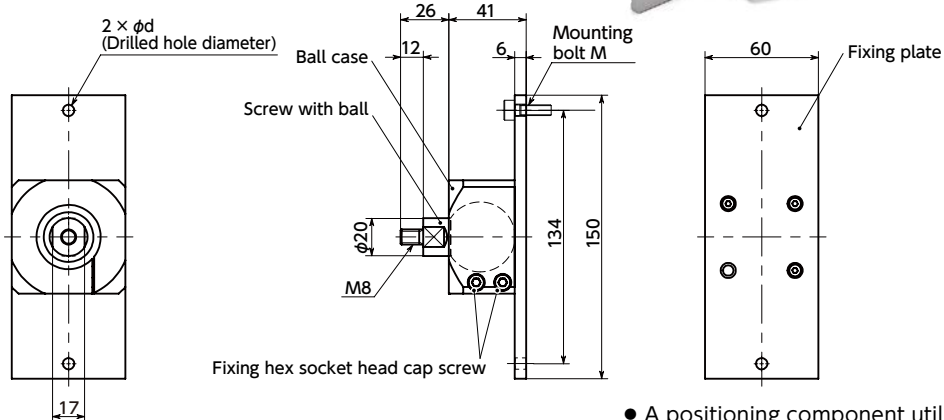

● Material/Finish



	DFKM-AF
Ball case	A6063 Anodized
Screw with ball	S45C Trivalent Chromate Treatment
Fixing Hex Socket Head Cap Screw (M5×16mm)	SCM435 Ferrosoferric Oxide Film
Fixing plate	SS400 Electrostatic Coating

- A positioning component utilizing a ball screw. Mount the workpiece to the screw at the ball tip for use.
- The screw with ball can be tilted by $\pm 15^\circ$ and rotated in any direction within 360° .
- By tightening the fixing hex socket head cap screw, securely retain the angle after adjustment.
- Can be mounted on aluminum frames, wall panels and sheet metal.
- Application

Machine tool / Medical equipment / FPD production device / Semiconductor manufacturing device / Packing machine / Food machinery

Unit : mm

Part Number 1	M*1	d	Tightening Torque *2 (N·m)	Fixing Hex Socket Head Cap Screw Tightening Torque Reference Value (N·m)	Screw With Ball Retention Torque *3 (N·m)	Max. Load Weight (kg)	Mass (g)
DFKM-60-M8-AF-M4	4	5	12.5	3	10	10	860
DFKM-60-M8-AF-M5	5	6	12.5	3	10	10	860
DFKM-60-M8-AF-M6	6	7	12.5	3	10	10	860
DFKM-60-M8-AF-M8	8	9	12.5	3	10	10	860

*1 : Mounting bolts are not supplied.

*2 : Screw tightening torque of the screw with ball.

*3 : Retention torque is the value indicated when the hex socket head cap screw is tightening to the torque indicated.

● Related Products

Female screw type **DFKF-AF**

DFKWF-AF with the same shape as **DFKM-AF** is available.

DFKF-AF → P.xxxx

DFKWF-AF → P.xxxx



DFKM-AA for mounting to aluminum frame end surfaces and **DFKM-PB** for mounting to round pipe are available.

DFKM-AA → P.xxxx

DFKM-PB → P.xxxx



- Part number specification

DFKM-60-M8-AF-M5

