

TAS-30

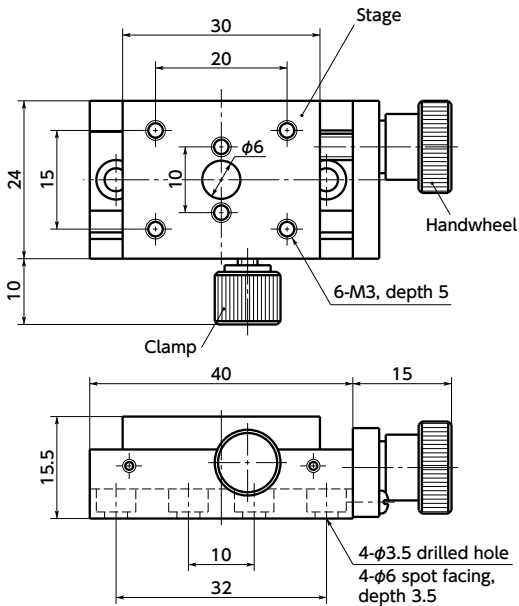

TAS-60

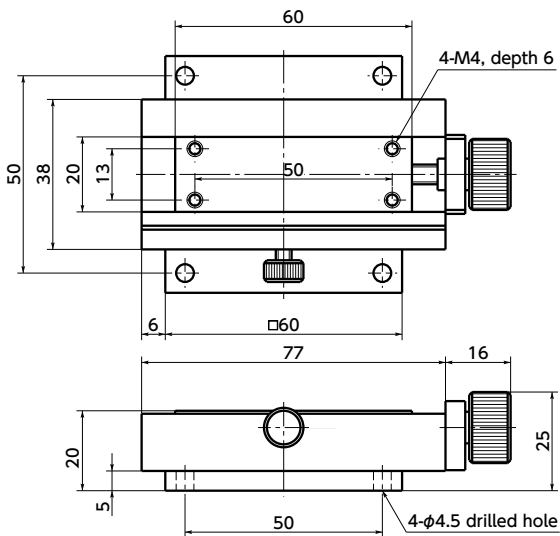

TAS-60



TAS-30



- Screws are used for micromotion feed.
- Dovetail groove method is adopted for the travel guide. A rattle correction function is provided.

• Material/Finish



	TAS-30	TAS-60
Stage	Brass Black chrome plating	Brass Black chrome plating
Main body	Brass Coating (Silver)	Brass Coating (Black)
Lower surface spacer	Aluminum Alloy Anodized (Black)	Aluminum Alloy Anodized (Black)

⚠ Precautions for Use

TAS-60 has the feeding handwheel above the stage surface. There may be interference depending on the shape of work fixed on the stage.

- Part number specification

TAS-30



Unit : mm

Part Number	Stage Face	Travel Guide	Travel Distance	Screw Pitch	Mass (g)
TAS-30	24×30	Dovetail Groove Method	±4	0.5	200
TAS-60	18×60	Dovetail Groove Method	±7.5	0.5	500

Unit : mm

Part Number	Straightness	Parallelism	Position Resolution	Withstand load (N)
TAS-30	0.02	0.05	0.01	68.7
TAS-60	0.02	0.05	0.01	147

- Pan head machine screws for mounting (M3 x 5 **TAS-30**) and hex socket head cap screw (M4 x 10 **TAS-60**) are provided.