

**TAR-80D**

**TAR-60D**

**TAR-80D**

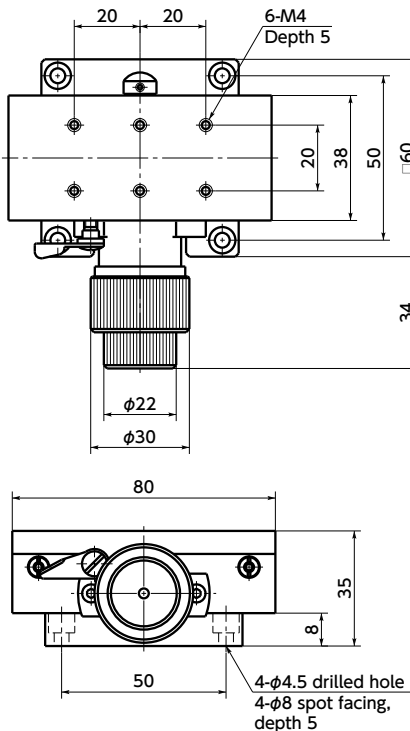
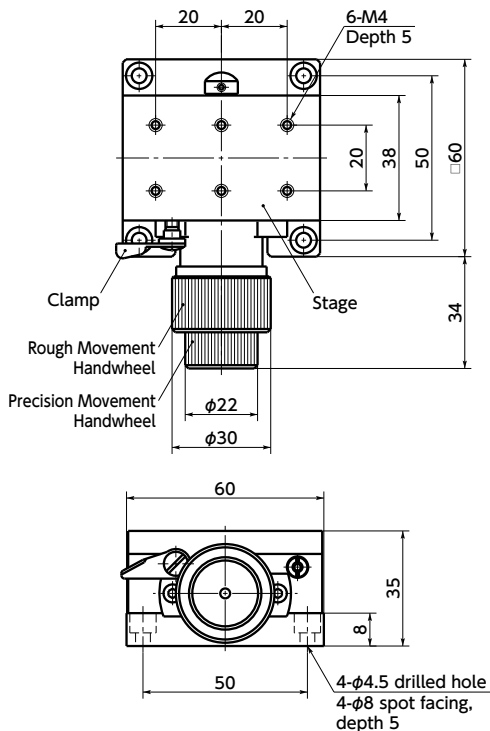

● Part number specification

## TAR-60D



- X-axis stage for rough and precision movement.
- Rough and precision adjustment can be made by using the coaxial handwheel.
- Dovetail groove method is adopted for the travel guide. A rattle correction function is provided.
- Material/Finish



	TAR-D
Stage	Brass Black chrome plating
Lower surface spacer	Aluminum Alloy Anodized (Black)

Part Number	Stage Face	Travel Guide	Travel Distance		Stroke (mm/Rotation)		Mass (g)
			Rough Movement Range	Precision Movement Range	Rough Movement Range	Precision Movement Range	
TAR-60D	38×60	Dovetail Groove Method	±15	±15	20	2.5	500
TAR-80D	38×80	Dovetail Groove Method	±25	±25	20	2.5	800

Unit : mm

Part Number	Straightness	Parallelism	Display Resolution	Position Resolution	Withstand load (N)
TAR-60D	0.02	0.06	0.1	0.02	147
TAR-80D	0.03	0.06	0.1	0.02	196

- Pan hex socket head cap screws for mounting (M4 x 8) are provided.