

TKSP-60

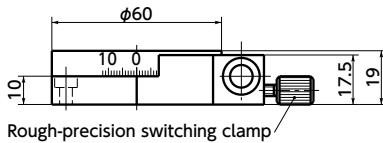

TAKS-100

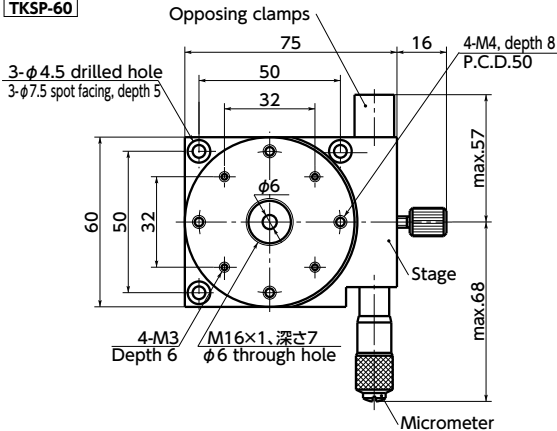
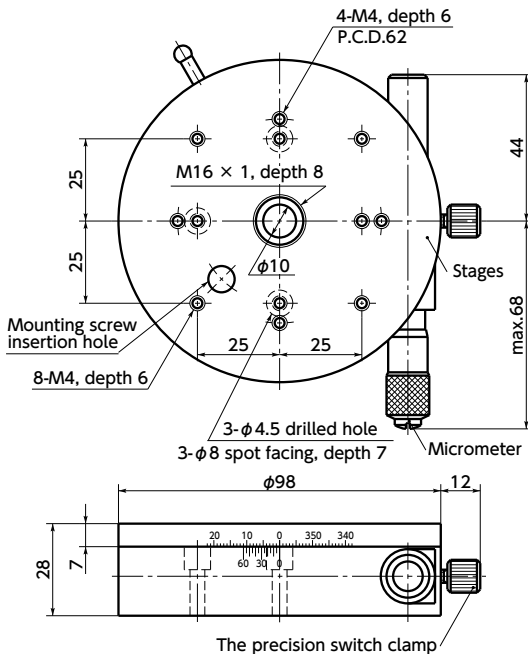

TAKS-100

- Rotary stage for rough and precision movement.
- Rough rotation when the precision switch clamp is loosened and precision rotation by micrometer when it is tightened to activated.
- The TKSP fine motion mechanism is equipped with opposing clamps enabling it to be locked.

● Material/Finish



	TKSP-60	TAKS-100
Stage	Brass Black chrome plating	Aluminum Alloy Anodized (Black)
Main body	Brass Black chrome plating	Aluminum Alloy Anodized (Black)

● Mounting

TAKS-100 has holes for mounting on the stage surface. Turn the stage surface, align the position with the mounting holes and insert screws.

● Part number specification

TKSP-60



Unit : mm

Part Number	Stage Face	Travel Guide	Range of Rotation		Mass (g)
			Rough Movement Range	Precision Movement Range	
TKSP-60	φ60	Lapping Method	360°	±5°	600
TAKS-100	φ98	Lapping Method	360°	±5°	700

Unit : mm

Part Number	Concentricity	Face Deflection	Parallelism	Display Resolution	Position Resolution	Withstand load (N)
TKSP-60	0.02	0.02	0.05	1'	1'	68.6
TAKS-100	0.02	0.02	0.05	5'	1'	68.6

● Pan hex socket head cap screws for mounting (M4 x 10 **TKSP-60**) and M4 x 20 **TAKS-100**) are provided.