

# MSX-C Flexible Couplings - Slit Type - Clamping Type

Zero Backlash High Rigidity

MSX-C Made of aluminum alloy

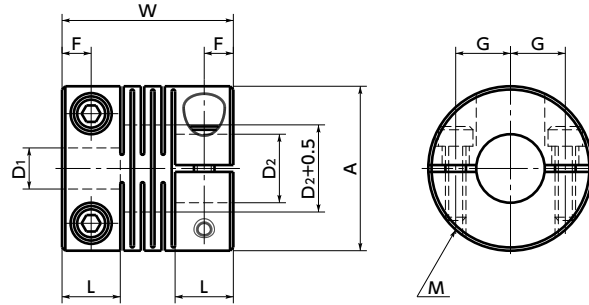

## Dimensions

Unit : mm

Part Number	A	L	W	F	G	M	Screw Tightening Torque (N·m)
MSX-16C	16	6	17.4	3	4.74	M2	0.5
MSX-19C	19	6.8	20	3.4	5.6	M2.5	1
MSX-24C	24	8.5	25	4.25	8	M3	1.5
MSX-29C	29	10.2	30	5.1	9	M3	1.5
MSX-34C	34	12	35	6	11	M3	1.5
MSX-39C	39	13.5	40	6.75	14	M4	2.5
MSX-44C	44	15.5	45	7.75	16	M4	2.5

Part Number	Standard Bore Diameter D1-D2							
MSX-16C	5 - 5	5 - 6	6 - 6					
MSX-19C	5 - 5 6.35 - 6.35	5 - 6 6.35 - 8	5 - 7 8 - 8	5 - 8	6 - 6	6 - 6.35	6 - 7	6 - 8
MSX-24C	6 - 6 8 - 9.525	6 - 8 8 - 10	6 - 10 9.525 - 10	6.35 - 6.35 10 - 10	6.35 - 8	6.35 - 10	7 - 8	8 - 8
MSX-29C	8 - 8 12 - 12	8 - 10	8 - 11	8 - 12	10 - 10	10 - 11	10 - 12	11 - 12
MSX-34C	10 - 14 15 - 15	11 - 14 15 - 16	12 - 12 16 - 16	12 - 14	12 - 16	14 - 14	14 - 15	14 - 16
MSX-39C	10 - 14 15 - 15	12 - 12 15 - 16	12 - 14 16 - 16	12 - 15	12 - 16	12 - 19	14 - 14	14 - 15
MSX-44C	12 - 12 15 - 19	12 - 14 15 - 20	12 - 19 20 - 20	14 - 14	14 - 15	14 - 16	15 - 15	15 - 16

- All products are provided with hex socket head cap screw.
- Recommended tolerance for shaft diameters is h6 and h7.
- For the shaft insertion amount to the coupling, see Mounting/maintenance.

### ⚠ Precautions for Use

- In case of mounting on D-cut shaft, be careful about the position of the D-cut surface of the shaft. → P.xxxx
- There are sizes where the hex socket head bolt exceeds the outer diameter of the coupling and the rotating diameter is larger than the outer diameter. Please be careful of the interference of coupling. → P.xxxx

## Performance

Part Number	Max. Bore Diameter (mm)	Rated *1 Torque (N·m)	Max. Rotational Frequency (min <sup>-1</sup> )	Moment *2 of Inertia (kg·m <sup>2</sup> )	Static Torsional Stiffness (N·m/rad)	Max. Lateral Misalignment (mm)	Max. Angular Misalignment (°)	Max. Axial Misalignment (mm)	Mass *2 (g)
MSX-16C	6	0.5	39000	2.5×10 <sup>-7</sup>	200	0.05	0.5	±0.1	7
MSX-19C	8	1	33000	5.8×10 <sup>-7</sup>	270	0.05	0.5	±0.1	12
MSX-24C	10	1.5	26000	1.8×10 <sup>-6</sup>	790	0.05	0.5	±0.1	23
MSX-29C	12	2	21000	4.7×10 <sup>-6</sup>	1400	0.05	0.5	±0.1	41
MSX-34C	16	3	18000	1.1×10 <sup>-5</sup>	2200	0.05	0.5	±0.1	62
MSX-39C	20	6	16000	2.3×10 <sup>-5</sup>	4100	0.05	0.5	±0.1	88
MSX-44C	22	9	14000	4.3×10 <sup>-5</sup>	5100	0.05	0.5	±0.1	128

\*1: Correction of rated torque due to load fluctuation is not required.

\*2: These are values with max. bore diameter.

- Part number specification

## MSX-39C-14-15



Additional Keyway at Shaft Hole → P.xxxx Cleanroom Wash & Packaging → P.xxxx Change to Stainless Steel Screw → P.xxxx

Bore additional modification only/ Add'l charge Please combine with Stainless Steel Screw Alteration Service Available / Add'l charge