

● Material/Finish



CUAB-A	
Bracket Body	A6063 Anodized
Cover	Aluminum Die Cast Electrostatic Coating (metallic silver)
Plate	Polyacetal (Black)
Push Button	Polyacetal (Black)
Setscrew	PC (Polycarbonate) (Transparent)

- Bracket for simple positioning when using vertical axis aluminum frames/square shafts.
- Mounting is possible from either the end or the side of the aluminum frame/square shaft.
- Push the push button to unlock the lock, smoothly move the bracket vertically, and release the push button to fix it in position.
- It can be moved upward without pushing the push button, just by applying force.
- The play with the aluminum frame or square shaft can be reduced through adjusting the setscrew screw-in depth.



- Load capacity of up to 5 kg.

● Specifications

Unit : mm

	CUAB-30-A	CUAB-40-A
Applicable Aluminum Frame/Square Shaft	□ 30±0.54	□ 40±0.60
Push Button Press Count Resistance*1	20,000 Times	

* 1 : Values are for reference only. They are not guaranteed values.

Part Number	L1	L	Max. Load Weight (kg)	Mass (g)
CUAB-30-A	29.5	69	5	420
CUAB-40-A	34.5	79	5	396

Unit : mm

⚠ Precautions for Use

- Mount to a vertical axis.
- **CUAB-A** requires vertical mounting. If mounted upside-down, **CUAB-A** cannot remain fixed onto aluminum frames/square shafts.
- **CUAB-A** is a product that uses friction fastening. In cases where oil, etc. adhered to the aluminum frame/square shaft causes the coefficient of friction to decrease or if impact loads or vibrations occur, the maximum load weight may decrease.
- When pressing the push button on **CUAB-A** to move the workpiece, make sure to support **CUAB-A** or the workpiece with both hands. Pressing the push button may cause a sudden drop, especially if a heavy object is loaded.
- The surface may be scratched depending on the material and surface treatment of the aluminum frame/square shaft.
- If excessive loads are applied, then the aluminum frame/square shaft may be scratched or **CUAB-A** may be damaged.
- Pressing the push button while wearing gloves could cause the glove material to get caught between the push button and bracket body. This may prevent the push button from being released, which will prevent the aluminum frame from being fixed in position.
- If forcefully screwed in, the setscrew will deform.



- Take care to pay attention to the vertical orientation when mounting.

● Related Products

Angle hinge that can be used in mounting is available.

Clamp Lever Retention Type

DFS-H

Hex Nut Retention Type

DFSN-H

Rotation Restriction Type

DKBR-H



● Part Number Specification

CUAB-30-A



● Mounting

● Aluminum Frame/Square Shaft Mounting Method (End Mounting)

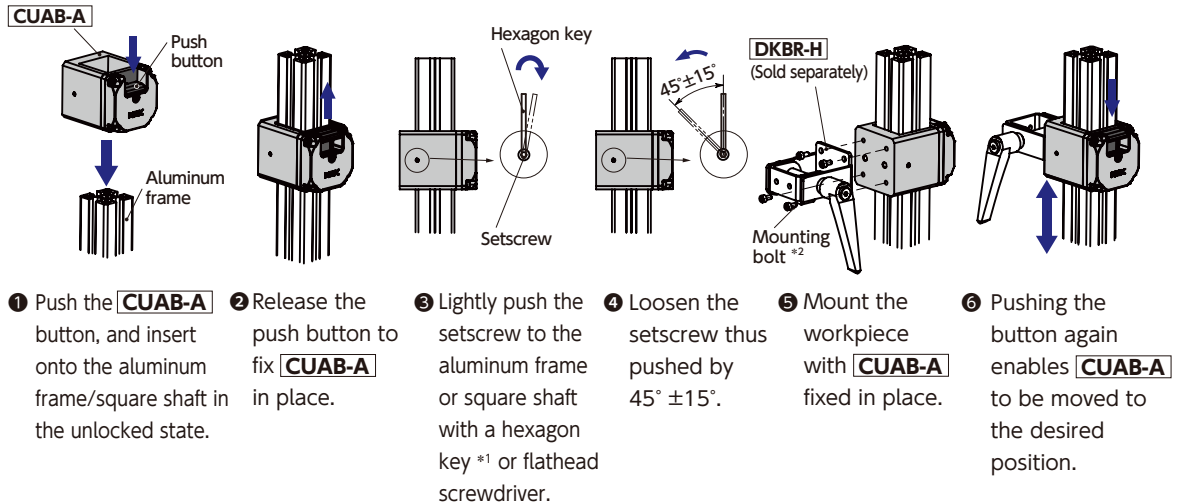

- 1 Push the **CUAB-A** button, and insert onto the aluminum frame/square shaft in the unlocked state.
- 2 Release the push button to fix **CUAB-A** in place.
- 3 Lightly push the setscrew to the aluminum frame or square shaft with a hexagon key *1 or flathead screwdriver.
- 4 Loosen the setscrew thus pushed by $45^\circ \pm 15^\circ$.
- 5 Mount the workpiece with **CUAB-A** fixed in place.
- 6 Pushing the button again enables **CUAB-A** to be moved to the desired position.

*1: The setscrew hex socket width across flat nominal is 1.3 mm.

*2: Mounting bolts are not supplied.

● Aluminum Frame/Square Shaft Mounting Method (Side Mounting)

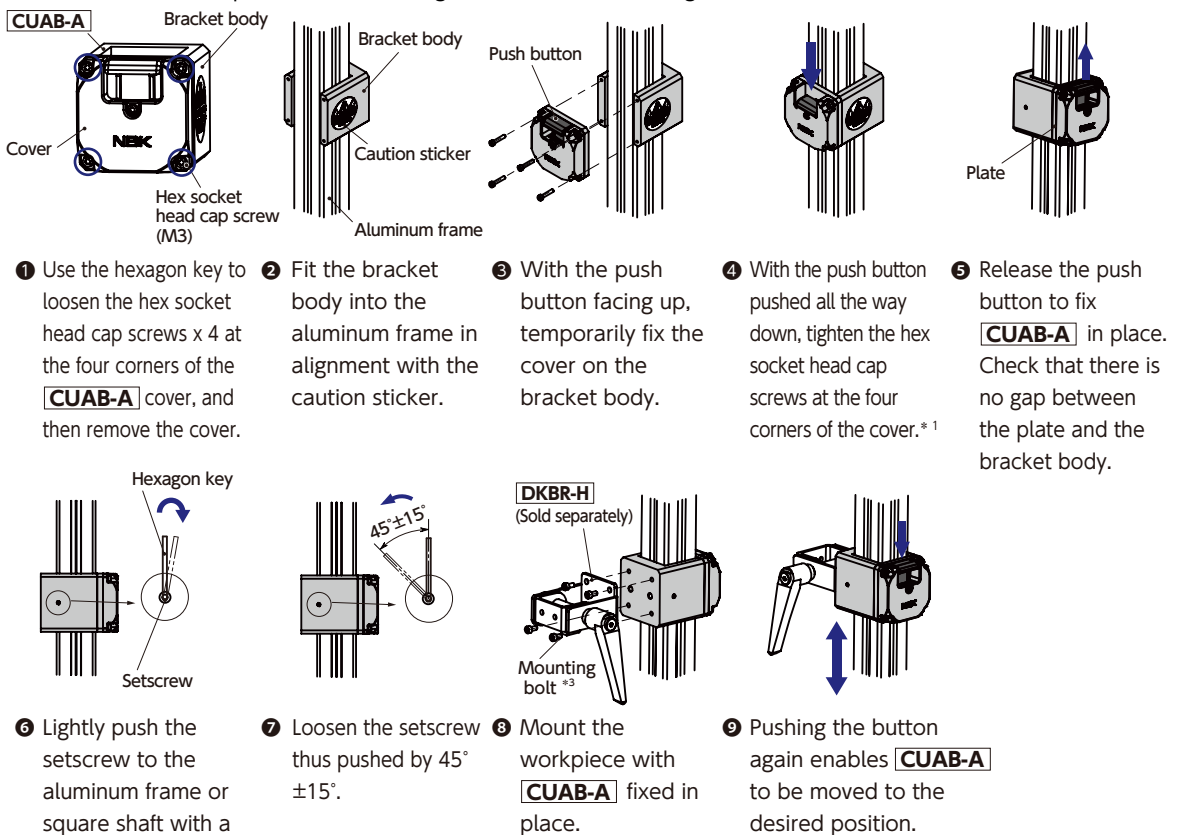

- 1 Use the hexagon key to loosen the hex socket head cap screws x 4 at the four corners of the **CUAB-A** cover, and then remove the cover.
- 2 Fit the bracket body into the aluminum frame in alignment with the caution sticker.
- 3 With the push button facing up, temporarily fix the cover on the bracket body.
- 4 With the push button pushed all the way down, tighten the hex socket head cap screws at the four corners of the cover.*1
- 5 Release the push button to fix **CUAB-A** in place. Check that there is no gap between the plate and the bracket body.
- 6 Lightly push the setscrew to the aluminum frame or square shaft with a hexagon key *2 or flathead screwdriver.
- 7 Loosen the setscrew thus pushed by $45^\circ \pm 15^\circ$.
- 8 Mount the workpiece with **CUAB-A** fixed in place.
- 9 Pushing the button again enables **CUAB-A** to be moved to the desired position.

*1: Tightening torque reference value: 0.315N·m

*2: The setscrew hex socket width across flat nominal is 1.3 mm.

*3: Mounting bolts are not supplied.