

# XBS-C / XBSS-C Flexible Couplings - Single - Disk Type - Clamping Type

Zero Backlash High Rigidity SUS Stainless steel

**XBS-C** Aluminum alloy hub  
**XBSS-C** Made of all stainless steel

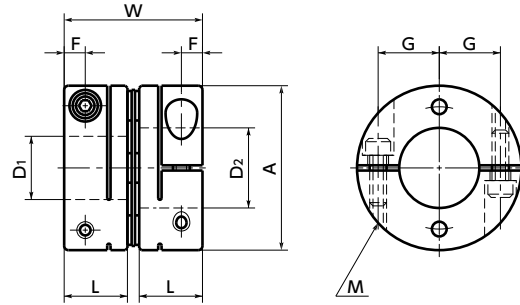

## Dimensions

Unit : mm

Part Number	A	L	W	F	G	M	Screw Tightening Torque (N·m)
XBS-15C2	15	7.5	16	2.3	5.25	M2	0.5
XBS-19C2	19	9	19	2.5	7.1	M2	0.5
XBS-25C2	25	11	23.6	3.5	9.25	M2.5	1
XBS-27C2	27	11	23.6	3.5	10.25	M2.5	1
XBS-34C3	34	12	26.2	4	13	M3	1.5
XBS-39C2	39	15	32.8	5	14.5	M4	3.5
XBS-44C2	44	15	32.8	5	17	M4	3.5
XBS-56C3	56	20	43.2	6	21.25	M5	8
XBS-68C5	68	24	53	7	25	M6	13
XBS-82C5	82	31	68	9	29.5	M8	30
XBS-94C7	94	31	68.8	9	35.5	M8	30
XBS-104C8	104	32	71.2	9	40.5	M8	30
XBSS-15C2A	15	7.5	16	2.3	5.25	M2	0.5
XBSS-19C2A	19	9	19	2.5	7.1	M2	0.5
XBSS-25C2A	25	11	23.6	3.5	9.25	M2.5	1
XBSS-27C2A	27	11	23.6	3.5	10.25	M2.5	1
XBSS-34C3A	34	12	26.2	4	13	M3	1.5
XBSS-39C2A	39	15	32.8	5	14.5	M4	3.5
XBSS-44C2A	44	15	32.8	5	17	M4	3.5
XBSS-56C3A	56	20	43.2	6	21.25	M5	8

Size	Standard Bore Diameter																										
	D1 / D2	3	4	5	6	8	10	11	12	14	15	16	18	19	20	22	24	25	28	30	32	35	38	40	42	45	50
15C2	●	●	●	●																							
19C2		●	●	●	●																						
25C2			●	●	●	●	●																				
27C2				●	●	●	●	●	●																		
34C3					●	●	●	●	●	●																	
39C2						●	●	●	●	●	●																
44C2							●	●	●	●	●	●															
56C3								●	●	●	●	●	●														
68C5*1									●	●	●	●	●	●													
82C5*1										●	●	●	●	●	●	●											
94C7*1											●	●	●	●	●	●	●										
104C8*1												●	●	●	●	●	●	●	●								

- All products are provided with hex socket head cap screw.
- Recommended tolerance for shaft diameters is h6 and h7.
- In case of mounting on D-cut shaft, be careful about the position of the D-cut surface of the shaft.
- For the shaft insertion amount to the coupling, see Mounting/maintenance.

\*1: This size is only for **XBS-C**.

Additional Keyway at Shaft Hole → P.xxxx    Cleanroom Wash & Packaging → P.xxxx    Change to Stainless Steel Screw → P.xxxx  
 Available / Add'l charge    Please feel free to contact us    Please feel free to contact us

## Performance

Part Number	Max. Bore Diameter (mm)	Rated <sup>*1</sup> Torque (N·m)	Max. Rotational Frequency (min <sup>-1</sup> )	Moment <sup>*2</sup> of Inertia (kg·m <sup>2</sup> )	Static Torsional Stiffness (N·m/rad)	Max. Lateral Misalignment (mm)	Max. Angular Misalignment (°)	Max. Axial Misalignment (mm)	Mass <sup>*2</sup> (g)
XBS-15C2	6	0.6	42000	9.8×10 <sup>-8</sup>	300	0.02	0.5	±0.1	5
XBS-19C2	8	1	33000	2.9×10 <sup>-7</sup>	600	0.02	1	±0.1	9
XBS-25C2	12	2	25000	1.1×10 <sup>-6</sup>	1300	0.02	1	±0.2	17
XBS-27C2	14	2.2	23000	1.4×10 <sup>-6</sup>	1600	0.02	1	±0.2	21
XBS-34C3	16	4.2	18000	4.0×10 <sup>-6</sup>	2500	0.02	1	±0.3	43
XBS-39C2	20	8	16000	9.8×10 <sup>-6</sup>	4600	0.02	1	±0.3	83
XBS-44C2	22	10	14000	1.6×10 <sup>-5</sup>	6000	0.02	1	±0.3	105
XBS-56C3	28	25	11000	5.7×10 <sup>-5</sup>	14000	0.02	1	±0.4	232
XBS-68C5	32	60	9000	1.6×10 <sup>-4</sup>	25000	0.02	1	±0.5	388
XBS-82C5	35	80	7000	4.2×10 <sup>-4</sup>	42000	0.02	1	±0.6	740
XBS-94C7	45	150	6000	6.9×10 <sup>-4</sup>	55000	0.02	1	±0.7	960
XBS-104C8	50	200	6000	1.1×10 <sup>-3</sup>	68000	0.02	1	±0.7	1180
XBSS-15C2A	6	0.42	42000	2.3×10 <sup>-7</sup>	500	0.02	0.5	±0.1	15
XBSS-19C2A	8	0.6	33000	7.4×10 <sup>-7</sup>	1000	0.02	1	±0.1	29
XBSS-25C2A	12	1.1	25000	2.8×10 <sup>-6</sup>	1500	0.02	1	±0.2	53
XBSS-27C2A	14	1.3	23000	3.8×10 <sup>-6</sup>	2100	0.02	1	±0.2	67
XBSS-34C3A	16	2.5	18000	1.1×10 <sup>-5</sup>	3800	0.02	1	±0.3	115
XBSS-39C2A	20	4.8	16000	2.3×10 <sup>-5</sup>	5500	0.02	1	±0.3	185
XBSS-44C2A	22	5.6	14000	3.9×10 <sup>-5</sup>	7000	0.02	1	±0.3	305
XBSS-56C3A	28	14	11000	1.4×10 <sup>-4</sup>	15000	0.02	1	±0.4	610

\*1: Correction of rated torque due to load fluctuation is not required.

※ The shaft's slip torque may be smaller than the coupling's rated torque depending on the shaft bore. → P.xxxx

\*2: These are values with max. bore diameter.

High-torque specification **XHS-C** is available. → P.xxxx

Rated Output (W)	Servomotor Type				Servomotor Specifications			Selection Size	
	Mitsubishi Electric Corporation	YASKAWA Electric Corporation	SANYO DENKI Co., Ltd.	KEYENCE CORPORATION	Diameter of Motor Shaft (mm)	Rated Torque (N·m)	Instantaneous Max. Torque (N·m)	XHS-C	XBS-C
100					8	0.32	1.1	XHS-19C	XBS-25C
200					14	0.64	2.2	XHS-27C	XBS-34C
400	HG-KR	SGMJV	R2	SV	14	1.3	4.5	XHS-34C	XBS-39C
750					16 - 19	2.4	8.4	XHS-39C	XBS-44C

• Part number specification

## XBS-39C2-12-14

